

SIGNODE **HBX-4300**TM **Small Anvil**

Semiautomatic plastic strapping machine for small bundles

- **Unmatched simplicity**
Easy to operate and maintain
- **Jam-resistant technology**
- **Designed to strap small, rigid bundles**



Model is shown with optional features.

Up to
70
straps per
minute!

SIGNODE[®]

SIGNODE HBX-4300™

Semiautomatic plastic strapping machine for small bundles
Small Anvil

The HBX-4300™ Small Anvil semiautomatic strapping machine, designed for small, irregular packages, provides reliable bundling for a wide range of applications. The HBX-4300 Small Anvil can strap rigid packages as small as 2-3/4" wide by 3/4" high. Built with a number of standard features to simplify maintenance and operation, the HBX-4300 maximizes production to save you time and money.

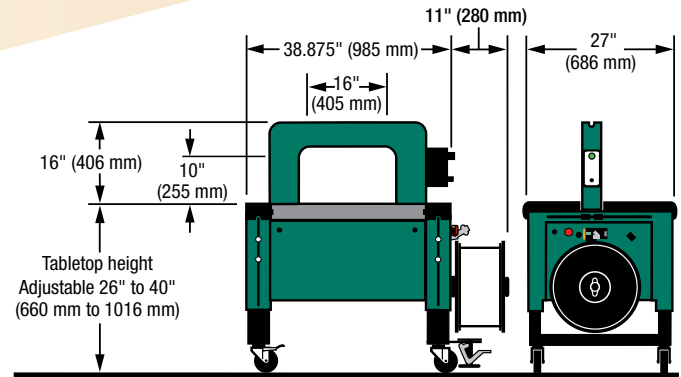
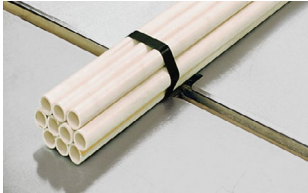

HBX-4300 Small Anvil chute inner dimensions
16 inches (406 mm) W x 10 inches (254 mm) H

Unmatched simplicity

The HBX-4300's simple yet durable design eliminates the use of drive belts and clutches. This combined with other trouble-free maintenance elements like toolless hot knife removal and jam-resistant technology make it easier to operate and more cost effective to maintain than other strapping machines.

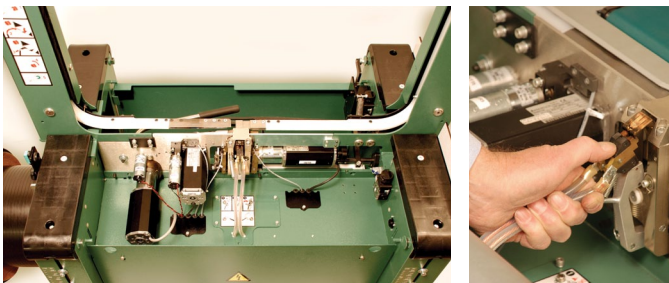

Bi-directional coil loading

Strap coil pays off from either direction, eliminating the downtime and material waste resulting from incorrect coil loading.

Out-of-strap feature

The out-of-strap feature ejects the strap at the end of the coil to eliminate downtime and errors associated with removing the excess strap left in the machine.

Fully accessible strap path

No tools required. Simply raise the tabletop and lift guide for access to strap path.

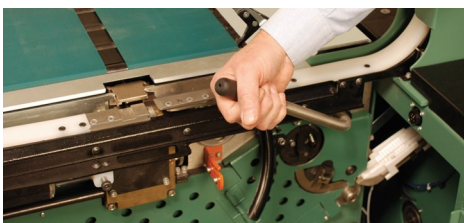

HBX-4300 Small Anvil Specifications

Cycle rate: Up to 70 straps per minute. Actual production will vary depending on package size, chute size and operator dexterity.
Minimum rigid package size: 2-3/4" (70 mm) W x 3/4" (19 mm) H
Maximum package size: 16" (405 mm) W x 10" (255 mm) H
Maximum package weight: 100 lbs
Maximum applied tension: Up to 250 lbs (1110 N)
Strapping: 9 mm or 12 mm Contrax polypropylene strapping
Electrical requirements: 120 volt, 60Hz, FLA 7 amp;
3 phase voltage optional
Shipping weight: 600 lbs

HBX-4300 Small Anvil Options

- EZ clear button
- EZ height adjustable leg kit — 26" to 40" (660 mm to 1015 mm)
- Floor lock kit
- Conveyor interlock kit

SIGNODE®

3610 West Lake Avenue
Glenview, Illinois 60026
1-800-323-2464
www.signode.com