

SIGNODE **LBX-2330 CP**TM

Automatic plastic strapping machine for copy paper

- **Unmatched simplicity**
Easy to operate and maintain
- **Jam-resistant technology**
- **Programmable controls**



Up to
70
straps per
minute!

Made in
the U.S.A.

SIGNODE[®]

SIGNODE LBX-2330CP™

Automatic plastic strapping machine for copy paper

The LBX-2330CP™ automatic strapping machine, designed for copy paper, provides maximum production uptime to save you time and money. The LBX-2330CP can be programmed for strap placement, box size and number of straps, minimizing downtime and operator intervention when modifying production parameters.



Strap feeds from either direction

Strap coil pays off from either direction, eliminating the downtime and material waste resulting from incorrect coil loading.

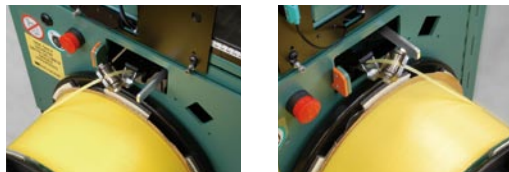

Out-of-strap feature

The out-of-strap feature ejects the strap at the end of the coil to eliminate downtime associated with removing the excess strap left in the machine.

Easy maintenance

No drive belts or clutches. Hot knife can be removed and cleaned without the use of any tools.



Fully accessible strap path

No tools required. Simply raise the tabletop and lift guide for access to strap path.



Toolless conveyor removal

Conveyors can be easily removed for maintenance.

Automatic cut-off and refeed option

Signode's patented automatic cut-off and refeed feature automatically ejects misfed strap, rethreads itself and continues strapping without operator intervention.

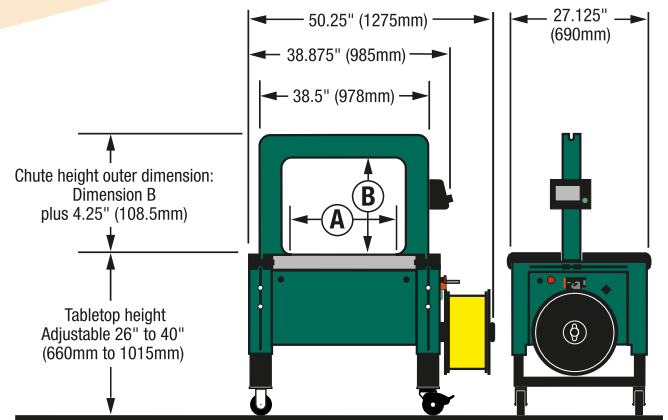

LBX-2330CP Chute inner dimensions

	in.	mm	in.	mm	in.	mm	in.	mm	in.	mm
A*	20	510	28	710	33	840	48	1220	48	1220
B	15	380	20	510	30	760	20	510	48	1220

*Inner dimension A is maximum package size.

LBX-2330CP Specifications

Cycle rate: Up to 70 straps per minute. Actual production will vary depending on package size, chute size and operator dexterity.

Maximum package weight: 100 lbs on machine or conveyors

Strapping: 5mm or 6mm polypropylene strapping

Strap tension: Adjustable from 2 lbs to 60 lbs

Electrical requirements:

208 volt, 60Hz, FLA 5.2 amp; 230 volt, 60Hz, FLA 4.7 amp; 460 volt, 60Hz, FLA 2.3 amp; 575 volt, 60Hz, FLA 2.0 amp

Shipping weight: 600 lbs

LBX-2330CP Options

- Single or dual compression
Single: Up to 120 lbs at 90 lbs psi
Dual: Up to 240 lbs at 90 lbs psi
- Indicator light alerts operator to low strap/out-of-strap conditions and machine malfunction
- EZ adjustable leg kit — 26" to 40" (660mm to 1015mm)
- Automatic cut-off and refeed
- Conveyor interlock kit

Save up to 20% on material costs with LB Series plastic strapping

The new LBX-2330CP utilizes Signode's newest Contrax® polypropylene strapping. LB Series strapping has the same durable properties as regular Contrax with more strap per coil.

- LB 112 5mm Contrax coils — 30,000 feet per coil
- LB 212 6mm Contrax coils — 24,000 feet per coil

SIGNODE®

3610 West Lake Avenue
Glenview, Illinois 60026
1-800-323-2464
www.signode.com